

# **DIRECTIONAL CONTROL VALVES**

## **DN 1-2**



**DINOIL S.p.A.**

*Via C. Colombo, 5 - I - 36075 MONTECCHIO MAGGIORE (VI)*

*Tel.: +39 0444705000 - Fax: +39 0444499005 - E-mail [dinoil@bypy.it](mailto:dinoil@bypy.it) - [www.bypy.it](http://www.bypy.it)*

Capitale sociale i.v. € 1.000.000 - Iscrizione registro imprese di Vicenza, c.f. e p.I.V.A. 00729680249  
Società appartenente al Gruppo Finsuge S.p.A. con sede in Suzzara (Mn)  
Iscrizione registro imprese di Mantova, c.f. e p.I.V.A. 01332540200

# DN 1-2

## MONOBLOCK DIRECTIONAL VALVES

### DATI TECNICI • TECHNICAL DATA • TECHNISCHE MERKMALE

Nominal flow (max)	45 (55) l/min 11.9 (14.5) gpm
Maximum pressure	300 (4351) bar (psi)
Maximum tank pressure	50 (730) bar (psi)
Maximum internal leakage	8 cc/min (21 cSt - 100 bar)
Work static temperature	-20°C +80°C NBR seals -20°C +130°C HNBR seals
Oil viscosity	From 10 cSt to 100 cSt
Fluid	Mineral based oil

### FILETTATURA • THREAD • GEWINDE

COD MODEL BEZEICHNUNG	TIPO TYPE GEWINDE	COPPIA DI SERRAGGIO Nm TORQUE Nm ANZUGSMOMENT Nm
M	M 18 X 1,5	40
1/2	1/2 Gas	70
E	3/4" UNF-16	50

### DIMENSIONI • SIZE • ABMESSUNGEN

MODEL	L mm	WEIGHT Kg (lb)
DN1	71	3.0 (6.6)
DN2	111	5.0 (11.0)

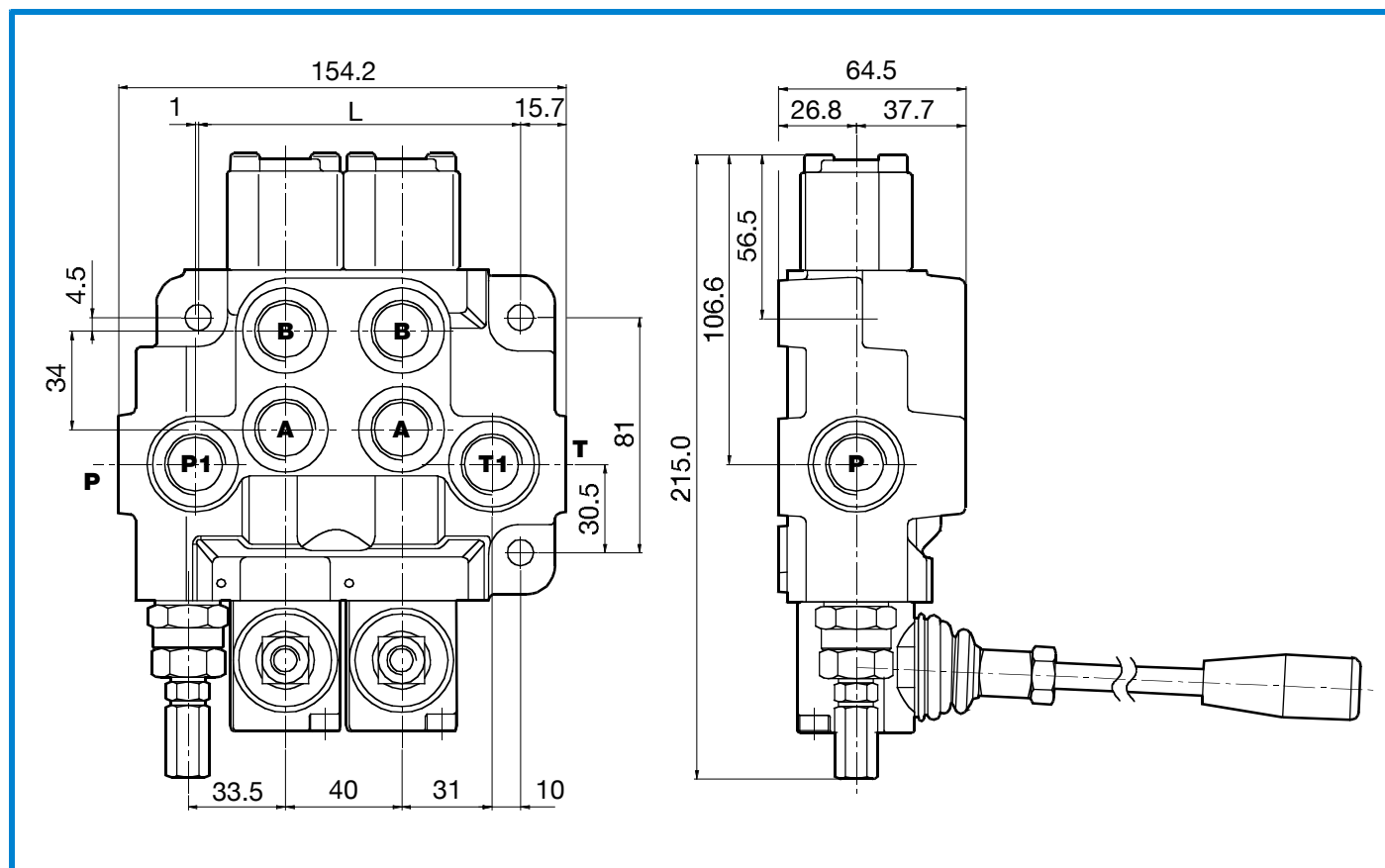
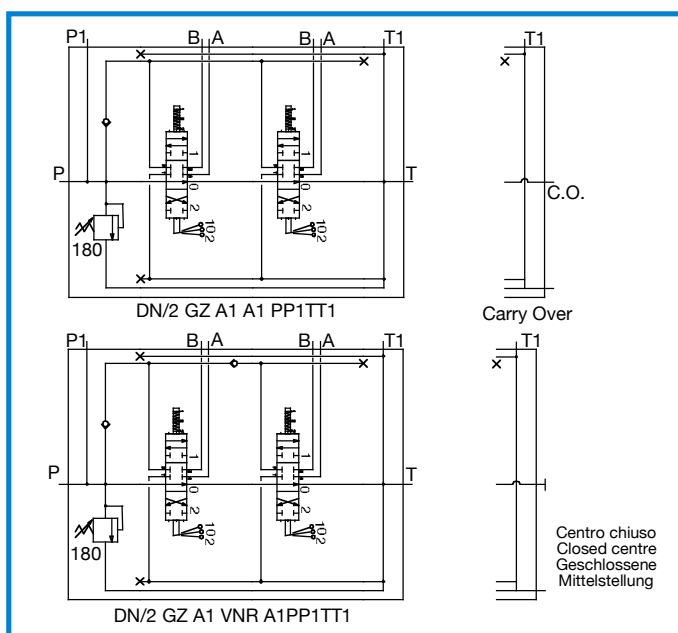



**CURVE CARATTERISTICHE  
CHARACTERISTIC BENDS  
TYPISCHE KURVEN**

**P-T**

DN 1 ———  
DN 2 - - - - -

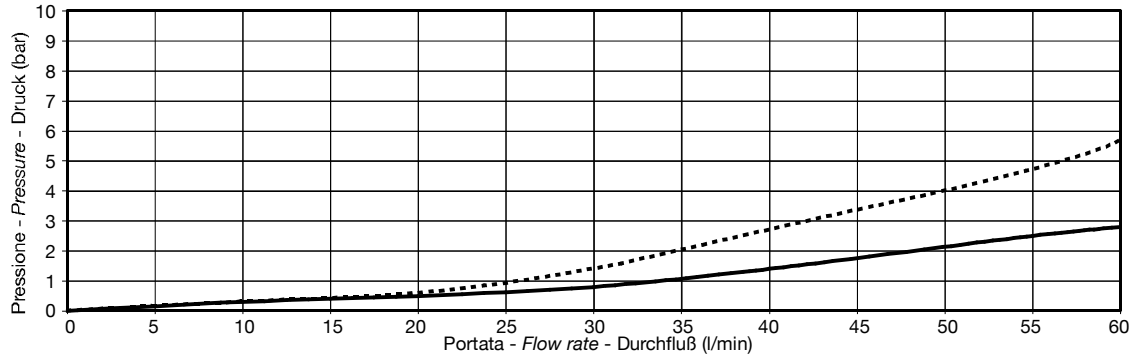
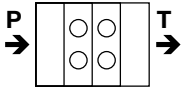

**P-A**

DN 1 ———  
DN 2 - - - - -  
VNR INTERMEDIA  
INTERMEDIATE VNR  
MIT RÜCKSCHLAGVENTIL  
DN 2 - - - - -  
NO VNR INTERMEDIA  
NO INTERMEDIATE VNR  
OHNE RÜCKSCHLAGVENTIL

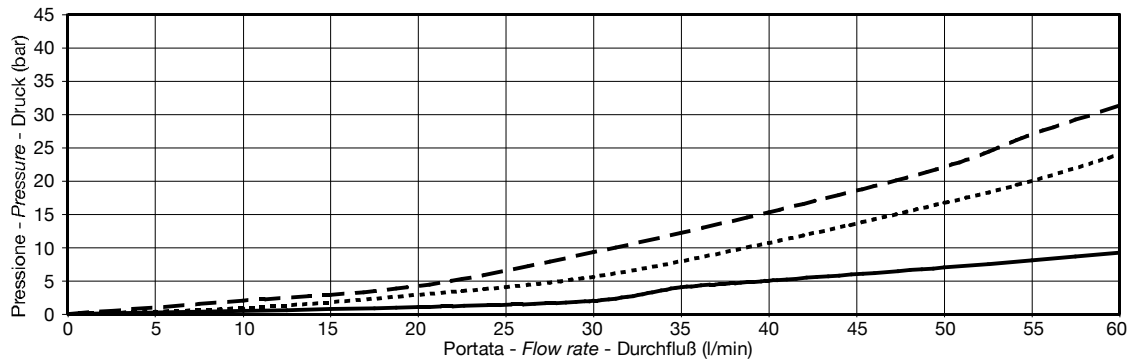
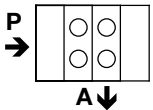

**B-T**

DN 1 ———  
DN 2 - - - - -

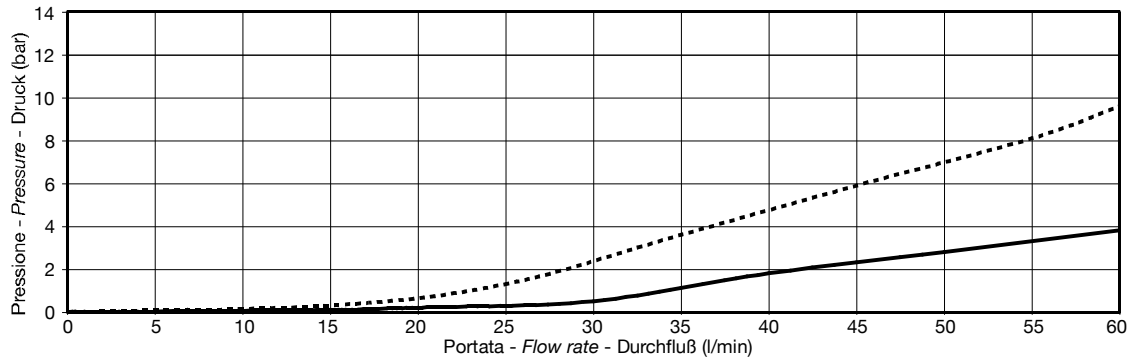
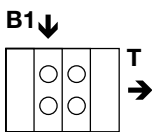

**METERING**

0 bar ———  
50 bar - - - - -  
100 bar - · - · - ·  
150 bar ·······

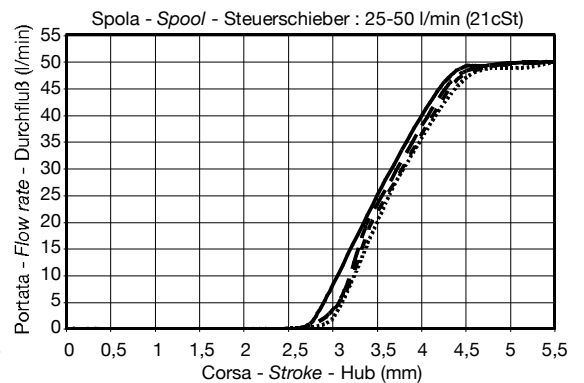
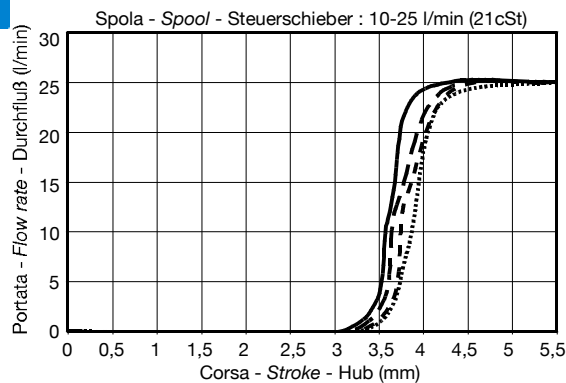

**CIRCUITI E SCHEMI IDRAULICI**  
**HYDRAULIC CIRCUITS AND SCHEMES**  
**STEUERTYPEN UND HYDRAULISCHE SCHEMATA**

POSIZIONATORE • SPOOL CONTROL • SCHIEBERSTELLUNG		
<b>A</b>		Posizione neutra in 0 <i>Neutral position in 0</i> Neutralstellung in 0
<b>B</b>		Posizione neutra in 0, detent in 1 <i>Neutral position in 0, detent in 1</i> Neutralstellung in 0, rastend in 1
<b>C</b>		Posizione neutra in 0, detent in 2 <i>Neutral position in 0, detent in 2</i> Neutralstellung in 0, rastend in 2
<b>D</b>		Detent in 0, 1, 2 <i>Detent in 0, 1, 2</i> Raststellung in 0, 1 und 2
<b>E</b>		Posizione neutra in 0 <i>Neutral position in 0</i> Neutralstellung in 0
<b>F</b>		Posizione neutra in 0 <i>Neutral position in 0</i> Neutralstellung in 0
<b>H</b>		Detent in 0, 2 <i>Detent in 0, 2</i> Raststellung in 0 und 2
<b>L</b>		Detent in 0, 1 <i>Detent in 0, 1</i> Raststellung in 0 und 1
<b>NT</b>		Posizione neutra in 0, detent in 4 <i>Neutral position in 0, detent in 4</i> Neutralstellung in 0, rastend in 4
<b>R</b>		Posizione neutra in 2 <i>Neutral position in 2</i> Neutralstellung in 2
<b>S</b>		Posizione neutra in 1 <i>Neutral position in 1</i> Neutralstellung in 1

CIRCUITO • SPOOL TYPE • STEUERTYP						
		POS. 3	POS. 1	POS. 0	POS. 2	POS. 4
<b>1</b>			P → B A → T BP →	P → T A → B BP →	P → A B → T BP →	
<b>3</b>			P → B A → T BP →	A, B → T P → BP →	P → A B → T BP →	
<b>4</b>			A → T P, B → BP →	P → T A → B BP →	P → A B, T → BP →	
<b>5</b>			P → B A, T → BP →	P → T A → B BP →	P, A → B → T BP →	
<b>70</b>			P → B A → T BP →	P → T A → B BP →	P → A B → T BP →	A, B → T P → BP →

**COMBINAZIONI • COMBINATIONS • KOMBINATIONEN**

**CONSIGLIATA • ADVISED**  
**EMPFOHLENER STEUERTYP**      **DISPONIBILE • AVAILABLE**  
**VERFÜGBARER STEUERTYP**

POSIZIONATORE SPOOL CONTROL SCHIEBERSTELLUNG	CIRCUITO • CIRCUIT • STEUERTYP				
	<b>1</b>	<b>3</b>	<b>4</b>	<b>5</b>	<b>70</b>
<b>A</b>	<input checked="" type="checkbox"/>	<input checked="" type="checkbox"/>	<input checked="" type="checkbox"/>	<input checked="" type="checkbox"/>	-
<b>B</b>	<input checked="" type="checkbox"/>	<input checked="" type="checkbox"/>	<input checked="" type="checkbox"/>	<input type="checkbox"/>	-
<b>C</b>	<input checked="" type="checkbox"/>	<input checked="" type="checkbox"/>	<input type="checkbox"/>	<input checked="" type="checkbox"/>	-
<b>D</b>	<input checked="" type="checkbox"/>	<input checked="" type="checkbox"/>	<input checked="" type="checkbox"/>	<input checked="" type="checkbox"/>	-
<b>E</b>	<input type="checkbox"/>	<input checked="" type="checkbox"/>	<input type="checkbox"/>	<input type="checkbox"/>	-
<b>F</b>	<input type="checkbox"/>	<input checked="" type="checkbox"/>	<input type="checkbox"/>	<input type="checkbox"/>	-
<b>H</b>	<input type="checkbox"/>	<input checked="" type="checkbox"/>	<input type="checkbox"/>	<input type="checkbox"/>	-
<b>L</b>	<input type="checkbox"/>	<input checked="" type="checkbox"/>	<input type="checkbox"/>	<input type="checkbox"/>	-
<b>NT</b>	-	-	-	-	<input checked="" type="checkbox"/>
<b>R</b>	<input checked="" type="checkbox"/>	<input checked="" type="checkbox"/>	<input type="checkbox"/>	<input type="checkbox"/>	-
<b>S</b>	<input checked="" type="checkbox"/>	<input checked="" type="checkbox"/>	<input type="checkbox"/>	<input type="checkbox"/>	-



**ISTRUZIONI PER L'ORDINAZIONE  
ORDERING INSTRUCTIONS  
BESTELLANLEITUNG**

